

Indicateur mécanique de position intégré de série sur tous les interrupteurs de 40 à 160A.  
*Integrated mechanical position indicator on switches from 40 to 160A.*

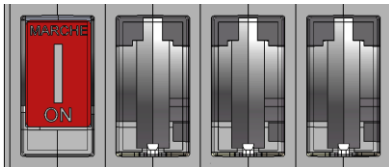

**COUPURE VISIBLE  
VISIBLE BREAKING**

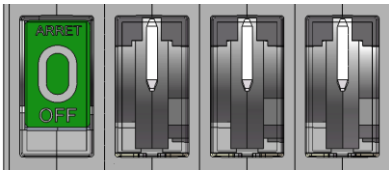

**INTERRUPTEUR OUVERT:  
VISION DES COUTEAUX  
SWITCH OPEN:  
VIEW OF THE CONTACTS**

**Solution économique adaptée à la plupart des exigences en milieu industriel.**  
*Cost-effective solution suitable for most requirements in industrial environment.*



INTER-SECTIONNEUR  
SWITCH-DISCONNECT.



COUPURE VISIBLE  
VISIBLE BREAKING



CDE LATÉRALE  
LATERAL HANDLE



DOUBLE VERROU  
DOUBLE LOCKING

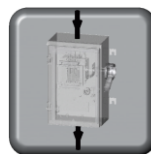

Racc. HAUT / BAS  
TOP/BOTTOM Conn.

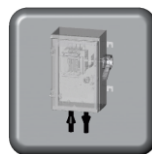

Racc. BAS / BAS  
BOT./BOTTOM Conn.

## APPLICATIONS

### Installation:

Intérieure et extérieure.

### Domaines d'utilisation:

L'industrie en général (ferroviaires, construction navale, sucreries, papeteries, secteur automobile, alimentaire...).

### Avantages de la gamme:

Résistance à la corrosion et ne nécessite pas d'entretien.  
Prix compétitif.

## CARACTERISTIQUES

### Interrupteurs-sectionneurs:

IM de 40 à 400A à commande latérale droite et coupure visible.

### Coupure visible:

Au travers d'un couvercle en polycarbonate transparent.

### Poignée de manœuvre:

Latérale isolante, couleur rouge, cadénassable par jusqu'à 3 cadenas en position circuit «ouvert» et indémontable de l'extérieur.

### Double verrouillage de porte:

Impossibilité d'ouvrir la porte lorsque l'interrupteur est fermé et impossibilité de fermer l'interrupteur lorsque la porte est ouverte.

### Fermeture de la porte:

Par vis isolantes aux angles de la cuve  
(autre solution sur demande).

### Raccordements:

Haut/Bas, Bas/Bas.

Pré câblage des bornes amont par jeu de barres à partir de 160A (Bas/Bas).

### Enveloppe:

- En polyester armé fibres de verre épaisseur 3 mm.
- Couleur gris clair RAL 7035.
- Porte en polycarbonate transparent auto-extinguible et exempt d'halogènes, montée sur charnières en inox (En plastique pour les 40A 3 pôles), autorisant une ouverture à gauche de 180°.
- Indice de protection:
  - IP 55 avec bouche d'aération en standard.
  - IP 65 sans bouche d'aération sur demande.
- Résistance à la température: - 35° à + 120°C.
- Résistance aux chocs IK10: 20 joules.
- Livré avec 4 pattes de fixation.

### Mise à la terre:

Deux points de mise à la terre à l'intérieur des coffrets.

## APPLICATIONS

### Installation:

Inside and outside.

### Main uses:

Industry in general (railway, naval, sugar, paper, car, food and beverage industries...).

### Advantages:

Resists to corrosion and does not require cleaning. Competitive price.

## CHARACTERISTICS

### Switch-disconnectors:

IM from 40 to 1600A with a right-hand side handle and visible breaking.

### Visible breaking:

Through a transparent polycarbonate cover.

### Control handle:

Laterally operated, insulating, red colour. It can be locked in "OFF" position with up to 3 padlocks. It cannot be removed from the outside.

### Double locking system:

Impossible to open the door when the switch is turned on and impossible to turn on the switch when the door is open.

### Door locking:

Using insulating screws on each angle of the box (other solutions on request).

### Connections:

Top/Bottom, Bottom/Bottom connection.

Pre-cabling of upper terminals by using connection bars from 160A (Bottom/Bottom).

### Box shell:

- With a 3 mm thick polyester fibre-glass.
- Colour grey RAL 7035.
- Auto-extinguishable transparent polycarbonate, halogen free, fixed on stainless steel hinges (Plastic for 3 poles 40A): allows to open the door at 180° on the left side.
- Protection degree:
  - IP 55 with air vent on standard.
  - IP 65 without air vent on request.
- Temperature resistance: - 35°C to + 120°C.
- Chock resistant grade IK10: 20 joules.
- Delivered with 4 wall fixations.

### Earth connection:

Using 2 earth connections inside the box.

**REFERENCES / REFERENCES**

**40A-3P**

**80A-3P**

Calibre Rating	Pôles Poles	Raccordement H/B Top/Bottom connection	Raccordement B/B Bot./Bottom connection
40A	3P	C508527	
	4P	J081566	
	6P	C202954	
63A	3P	L081568	
	4P	M081569	
	6P	R205221	
80A	3P	P081571	
	4P	Q081572	
	6P	S203060	
160A	3P	Q093026	N090839
	4P	R093027	P090840
200A	3P	J090812	M090723
	4P	K090813	O090807
315A	3P	X202995	S202991
400A	3P	C600504	Y090825

**Courants assignés d'emploi Ie (A) / Rated operational current Ie (A)**

Tension assignée d'emploi Rated operational voltage	Catégorie d'emploi Utilization category	40A	63A	80A	160A	200A	315A	400A
< 500VAC	AC-21	40	63	80	160	200	315	400
	AC-22	40	63	80	160	200	315	400
	AC-23	40	63	63	125	200	315	400
690VAC	AC-21	40	63	80	160	200	315	400
	AC-22	40	63	80	160	200	315	400
	AC-23	-	-	-	125	200	315	400
1000VAC	AC-21	-	-	-	-	200	315	400
	AC-22	-	-	-	-	200	315	400
	AC-23	-	-	-	-	135	200	200

**Puissance moteur (kW) / Motor power (kW)**

à / to 400VAC	22	30	30	69	110	160	220
à / to 500VAC	27	43	43	87	132	220	280
à / to 690VAC	-	-	-	119	200	315	400
à / to 1000VAC	-	-	-	-	208	327	415

Les coffrets de sécurité sont livrés en standard sans bouton poussoir ni contact-auxiliaire. Nous personnalisons les coffrets sur demande, veuillez nous consulter. Autres calibres et nombres de pôles sur demande.

*On standard, safety enclosures are offered without auxiliary contact or push button. The equipment is customized upon request according to your specification; please contact us .Other sizes and numbers of poles on request.*

**DIMENSIONS / DIMENSIONS**

**POLY-M Polyester & Makrolon 40 - 3P**  
**POLY-M Polyester & Makrolon 40 - 3P**

Calibre Rating	Haut/Bas Top/Bottom	Bas/Bas Bot./Bottom	Section racc.maxi Max connect. section (mm <sup>2</sup> )
	Poids Weight (kg)		
40A	2.7		16

Raccordement: par cage  
Connection shell

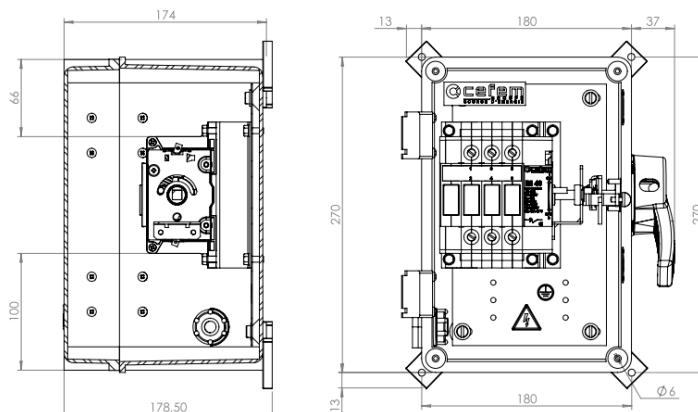
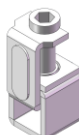

**POLY-M Polyester & Makrolon 63 à 80A - 3P**  
**POLY-M Polyester & Makrolon 63 to 80A - 3P**

Calibre Rating	Haut/Bas Top/Bottom	Bas/Bas Bot./Bottom	Section racc.maxi Max connect. section (mm <sup>2</sup> )
	Poids Weight (kg)		
63A	2.7		25
80A	2.7		25

Raccordement: par cage  
Connection shell

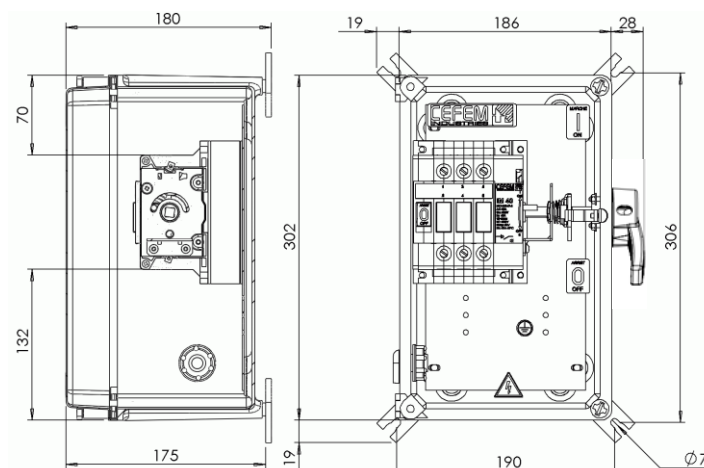
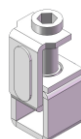

**POLY-M Polyester & Makrolon 40 à 80A - 4 à 6P**  
**POLY-M Polyester & Makrolon 40 to 80A - 4 to 6P**

Calibre Rating	Haut/Bas Top/Bottom	Bas/Bas Bot./Bottom	Section racc.maxi Max connect. section (mm <sup>2</sup> )
	Poids Weight (kg)		
40A	4.1		16
63A	4.1		25
80A	4.1		25

Raccordement: par cage  
Connection shell

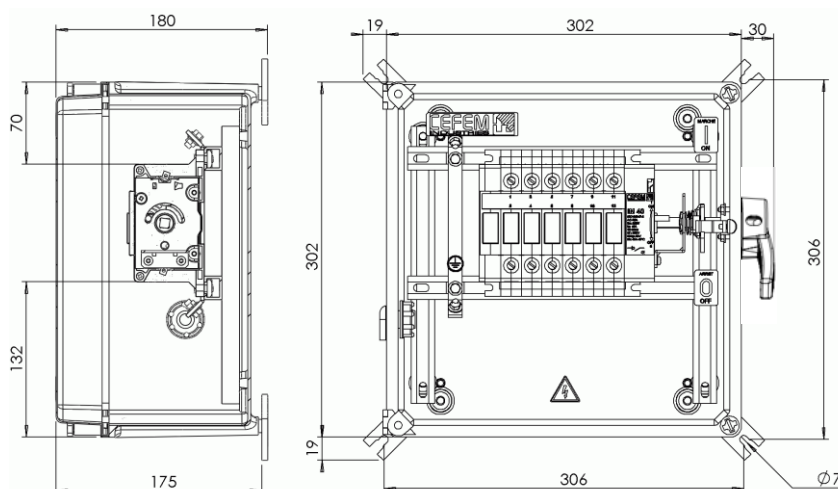
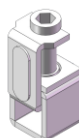

**POLY-M Polyester & Makrolon 160 à 200A - 3P**  
*POLY-M Polyester & Makrolon 160 to 200A - 3P*

Calibre Rating	Haut/Bas Top/Bottom	Bas/Bas Bot./Bottom	Section racc.maxi Max connect. section (mm <sup>2</sup> )
	Poids Weight (kg)		
160A	4.6	4.8	50
200A	4.8	5	50

Raccordement: plages largeur 20mm, vis M8  
Connection bars: 20 mm width, screw M8

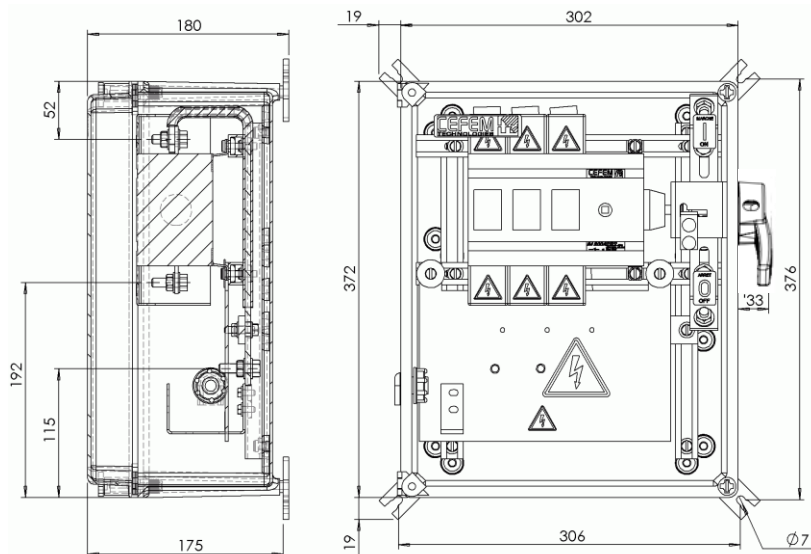
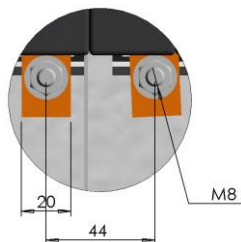

**POLY-M Polyester & Makrolon 160 à 200A - 4P**  
*POLY-M Polyester & Makrolon 160 to 200A - 4P*

Calibre Rating	Haut/Bas Top/Bottom	Bas/Bas Bot./Bottom	Section racc.maxi Max connect. section (mm <sup>2</sup> )
	Poids Weight (kg)		
160A	9.8	10	50
200A	10.8	11	50

Raccordement: plages largeur 20mm, vis M8  
Connection bars: 20 mm width, screw M8

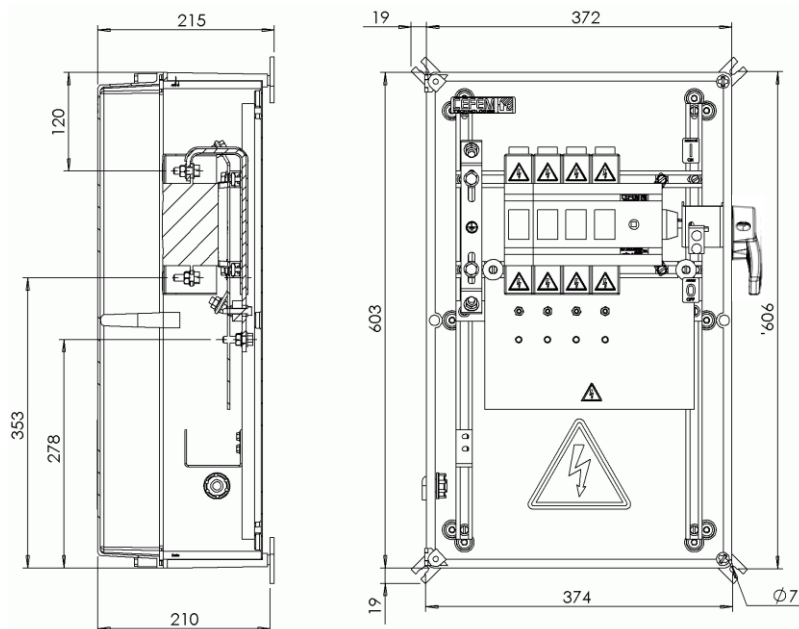
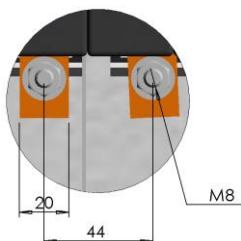

**POLY-M Polyester & Makrolon 315 à 400A - 3P**  
*POLY-M Polyester & Makrolon 315 to 400A - 3P*

Calibre Rating	Haut/Bas Top/Bottom	Bas/Bas Bot./Bottom	Section racc.maxi Max connect. section (mm <sup>2</sup> )
	Poids Weight (kg)		
315A	11.2	11.4	150
400A	12.4	12.6	185

Raccordement: plages largeur 25mm, vis M10  
Connection bars: 25 mm width, screw M10

